

series
300
2-Stage Servo Valve
Rated flows up to 19 l/m

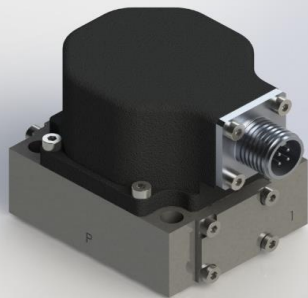

Features

- Miniature design
- Maximum operating pressure 315 bar
- ISO 10372-02-02-0-92 mounting pattern
- Internal pilot supply (4 port)
- Suitable for 3-way or 4-way applications
- Low hysteresis & zero point drift
- High spool drive forces
- Dry torque motor with mechanical feedback
- Long life Sapphire Technology



Star Hydraulics Limited
Severn Drive
Tewkesbury Business Park
Tewkesbury
Gloucestershire
GL20 8SF
England (UK)

www.star-hydraulics.co.uk

ST-300-2018.1-En

Benefits and Features

Sapphire ball in slot design

- Incorporated into Star designs since 1988
- Many billions of cycles per service life
- Increased spool life due to spool rotation
- Ultra low coefficient of friction sapphire to steel
- Feedback mechanism unhindered by spool rotation
- Extended warranties available



Safety

- Flame proof
- Intrinsic safety
- Class, Div & Zone coverage
- Mechanical failsafe
- Double & triple coil redundancy



Quality



- Independent audit process is our commitment on quality
- Focus on customer needs and expectations
- Delivery schedules on time
- Continual improvements on products and services
- Maintaining design and manufacturing integrity

Custom spool lap & bushing port geometries

- Zero overlap
- Overlap (closed center)
- Underlap (open center)
- Dual gain
- Asymmetric gain

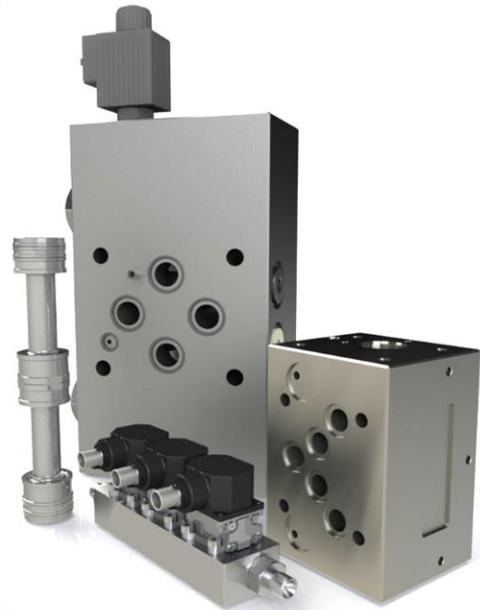
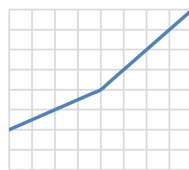
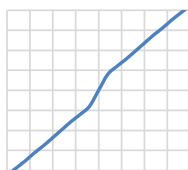
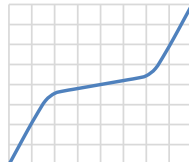
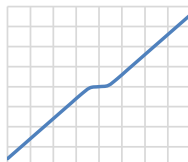
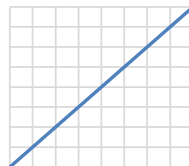

Special projects

- Compact servo designs
- Special interfaces
- Modular components



Sealing materials

- Nitrile
- Fluorocarbon (Viton)
- Ethylene-Propylene
- Fluorosilicone

Sapphire flow

- Ensuring first stage stability
- Precisely matched flow properties
- Long life in extreme environments



Special connectors

- MIL-C-5015
- MIL-DTL-38999
- Conduit style male/female
- Hermetic

Technical data

Hydraulic

Nominal flow ratings [$\pm 10\%$]	at 70 bar Δp	2, 4, 10, 19 l/m
Operating pressure (max)	Ports	P, C1, C2, R
Seal material	NBR, FPM	315 bar
	EPDM	210 bar
Fluid viscosity range (recommended)		10 to 100 mm ² /s (cSt)
Fluid type		Mineral oil to ISO 11158, DIN 51524 or equivalent MIL-H-5606 Skydrol Kerosene Water glycols others on request
Filter rating (recommended)	Pressure line	Beta 10 = 200 (10 μ m abs), non by-pass & indicator
	Off-line	Beta 2 = 1000 (2 μ m abs)
Fluid cleanliness	ISO 4406: 1999	
	minimum	16/ 14/ 11
	recommended	15/ 13/ 10

Operational parameters

Hysteresis		$\leq 3.0\%$ without dither
Threshold		$\leq 0.5\%$ without dither
Null shift	$\Delta T 40^\circ C$	$\leq 2.0\%$
Internal leakage	140 bar supply (0.5% overlap)	
	2, 4, 10 l/m	≤ 1.2 l/m
	20 l/m	≤ 1.6 l/m
Load pressure difference	1% input	$\geq 30\%$ of supply pressure can be as high as 100%
Response time	0-100% rated spool stroke	4.5 ms
Mounting pattern		ISO 10372-02-02-0-92
Mounting position		Any, fixed or movable
Weight	std unit	0.51 kg
Design protection	EN 60529	IP 65
Shipping protection		Sealed base plate
Vibration		30 g all axis, 5 Hz to 2,000 Hz
Shock		30 g all axis
Seal material options		NBR, FPM, EPDM
Temperature range		-30 to 135 $^\circ C$

Technical data

type: Amphenol style PC02_8-4P

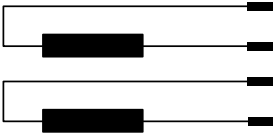
Rated input ± (mA)	single (differential)	8	15	30	40	100	200
Other coil rates available	series	4	7.5	15	20	50	100
	parallel	8	15	30	40	100	200
Coil resistance (Ω)	per coil	1000	200	300	80	28	22
Power (W)	single	0.064	0.045	0.27	0.128	0.280	0.88
	series	0.032	0.023	0.135	0.064	0.140	0.440
	parallel	0.032	0.023	0.135	0.064	0.140	0.440
Connector pin out identification		A B C D					
Polarity P»C2, C1»R	single	A +, B - or C +, D -					
	series	A +, D -, B & C linked					
	parallel	A & C linked +, B & D linked -					
Valve connector type	MIL-C-26482	PC02E8-4P mates with PC06E8-4S Consult factory for more options					
Standard connector orientation	also available over	N/A C2, C1 port; please advise when ordering					

Technical data

Electrical connection type: Flying lead

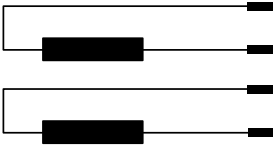
Rated input ± (mA)	single (differential)	10	30	40
	series	5	15	20
	parallel	10	30	40
Coil resistance (Ω)	per coil	1000	300	80
Power (W)	single	0.1	0.270	0.128
	series	0.050	0.135	0.064
	parallel	0.050	0.135	0.064
Inductance (H)	single	1.82	0.31	0.1
	series	5.7	0.88	0.3
	parallel	1.44	0.22	0.07
Coil lead out identification		Blue Red White Black	White Red Green Yellow	Green Red Yellow Blue
Polarity P»C2, C1»R	single	Blue +, Red - or White +, Black -	White +, Red - or Green +, Yellow -	Green +, Red - Yellow +, Blue -
	series	Blue +, Black -, link Red & White	White +, Yellow -, link Red & Green	Green +, Blue - link Red & Yellow
	parallel	link Blue & White +, link Red & Black -	link White & Green +, link Red & Green -	link Green & Yellow + link Red & Blue -
Valve connection type		PTFE type A O/D 0.82 mm, core 7/0.15 mm 26 AWG 600 mm long flying lead		
Standard connector orientation		N/A		
	available over	P or R port; please advise when ordering		

Technical data

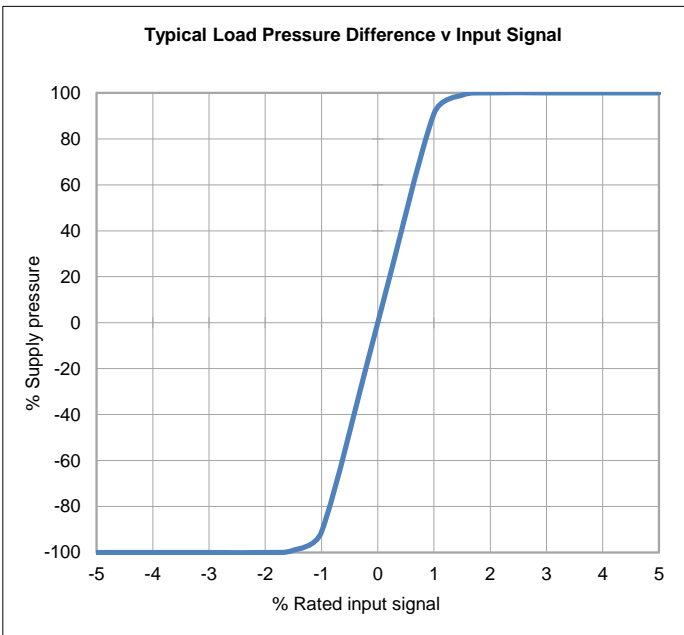
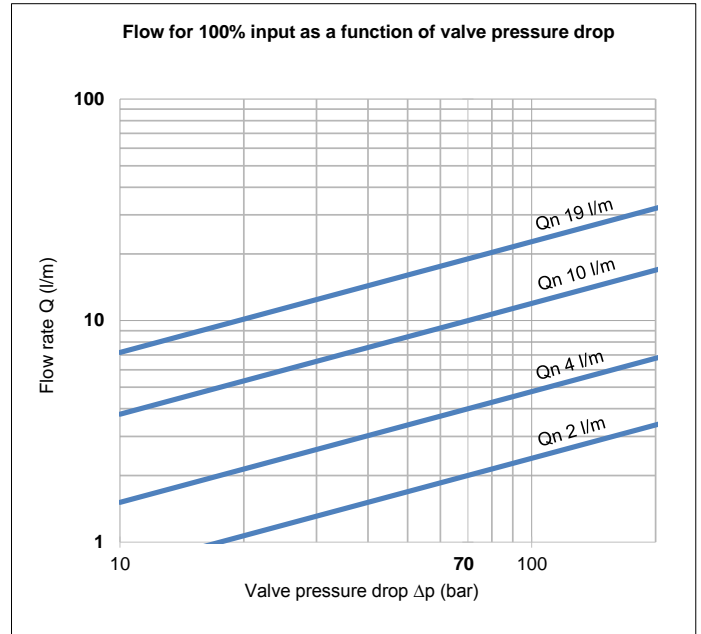
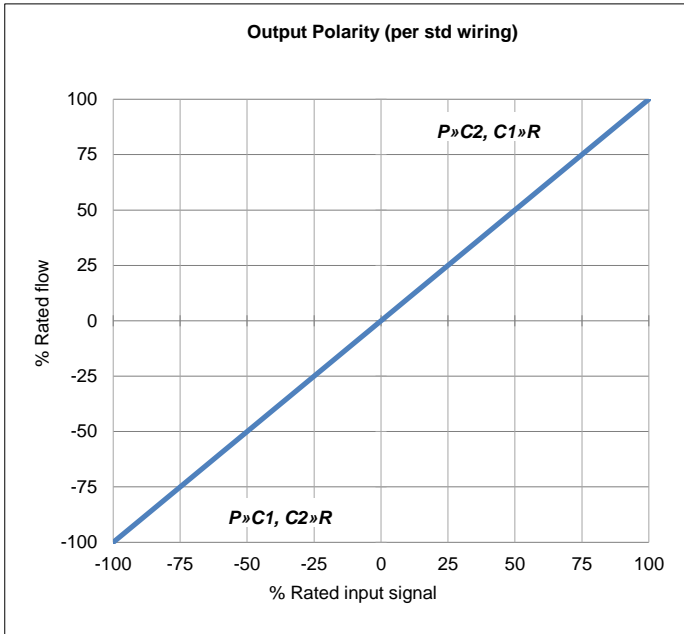

The flow tolerance for standard servovalves is $\pm 10\%$ of the rated flow at 100% rated input signal.

Rated Signal [In] is the specified input voltage or current of either polarity to produce rated flow. Rated input does not include null bias values.

Rated flow corresponds to the flow at rated input at 10 bar or 70 bar, with no load, therefore in 4-way valves there will be a pressure drop of 5 bar or 35 bar respectively across each land.

Load pressure difference versus input signal indicates typical differential pressure gain between ports C1 (A) and C2 (B) for standard lap spools. Negative and positive overlap change this characteristic significantly.

Internal leakage comprises of tare first stage and laminar leakage between spool and sleeve. With critical lap conditions in 4-way designs the leakage peaks through the null region.

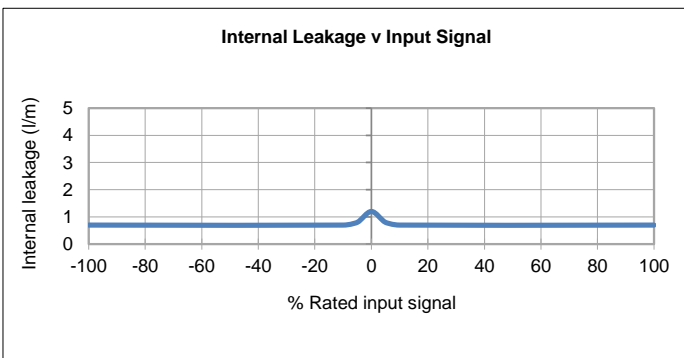

Technical data

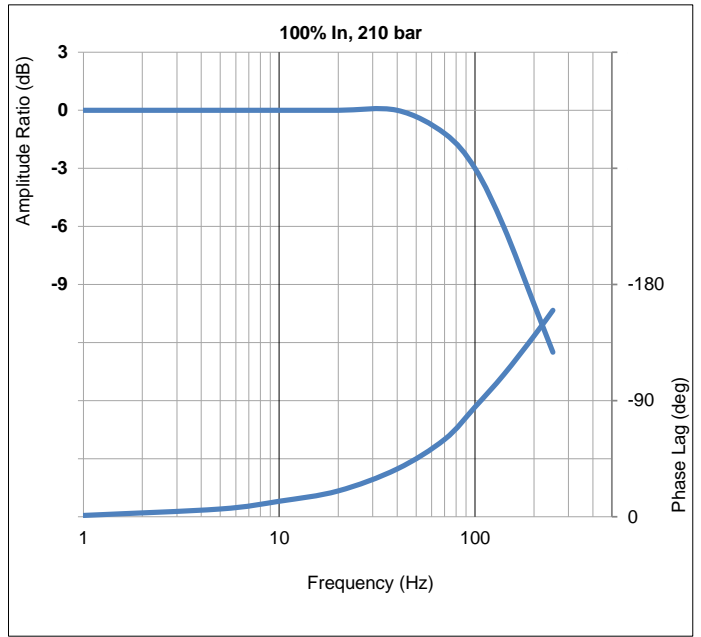
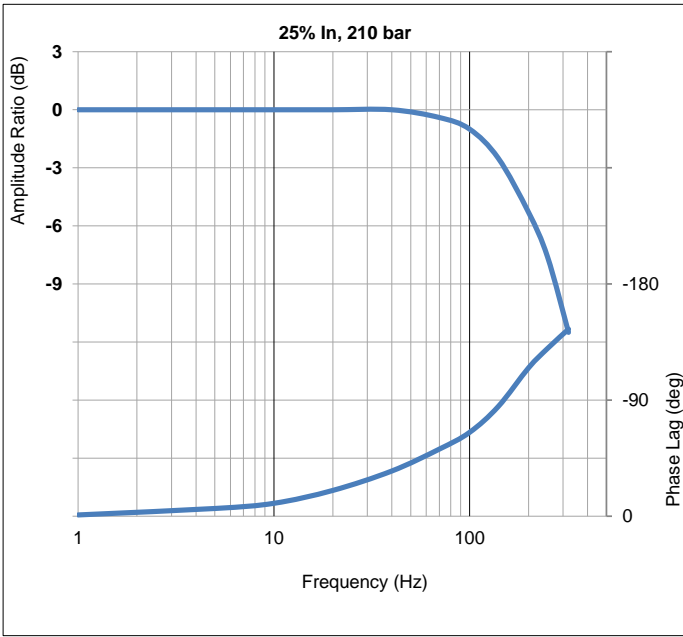

300 series
INSTALLATION DETAILS



Mounting screws	Skt head cap screws M5 x 30 ISO 4762
Porting details	P, C1, C2, R ports $\varnothing 6.0$, \perp $\varnothing 10.6$ $\nabla 1.40$ on 15.8 P.C.D.
Interface seals	Ports P, C1, C2, R - ID 7.66 x $\varnothing 1.78$ O-Ring
Electrical connection	Amphenol style PC02_8-4P

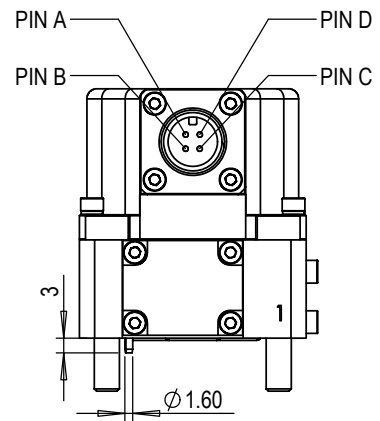
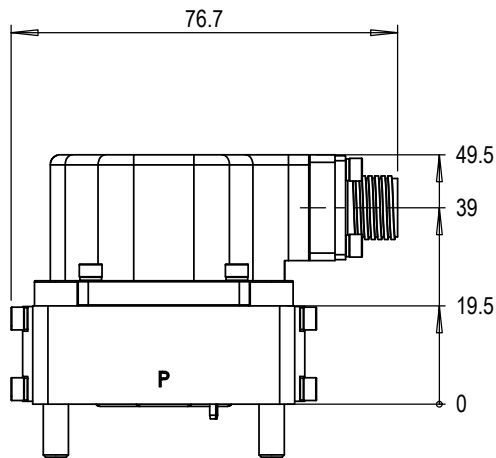
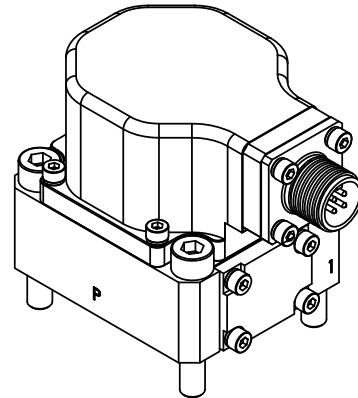
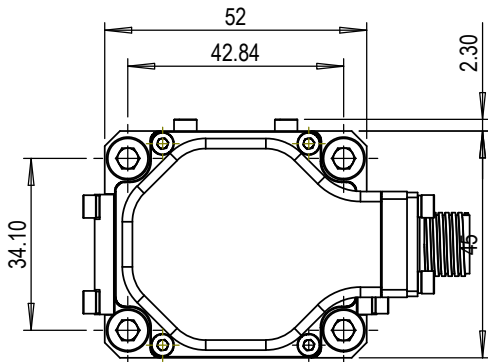

Mounting interface conforms to ISO 10372-02-02-0-92									
	P	C1	C2	R	F1	F2	F3	F4	G
size	$\varnothing 5$	$\varnothing 5$	$\varnothing 5$	$\varnothing 5$	M5	M5	M5	M5	$\varnothing 3 \nabla 5$
x	21.40	13.50	29.30	21.40	0	42.80	42.80	0	11.50
y	9.20	17.10	17.10	25	0	0	34.20	34.20	4.40
Surface flat within 0.01 / 100 : finish better than 0.8 μm									

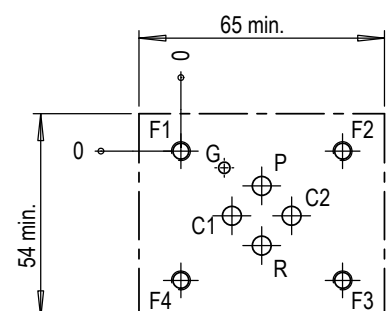

300 series
INSTALLATION DETAILS



Mounting screws	Skt head cap screws M5 x 30 ISO 4762
Porting details	P, C1, C2, R ports $\varnothing 6.0$, \perp $\varnothing 10.6$ $\nabla 1.40$ on 15.8 P.C.D.
Interface seals	Ports P, C1, C2, R - ID 7.66 x $\varnothing 1.78$ O-Ring
Electrical connection	Flying lead, lead colours vary with coil rate

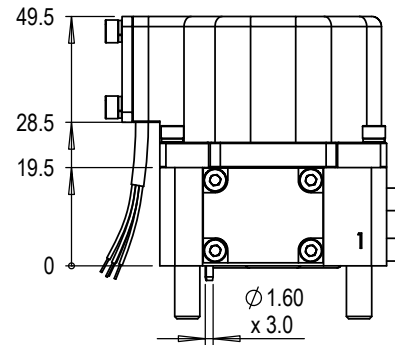
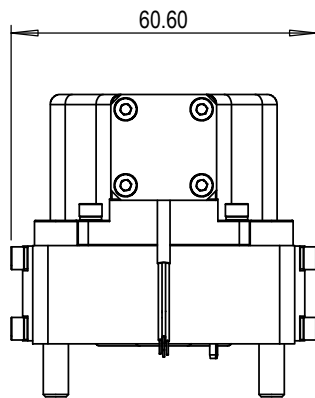
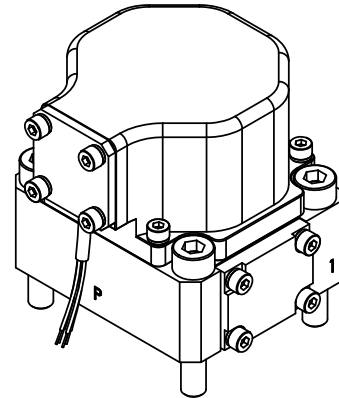
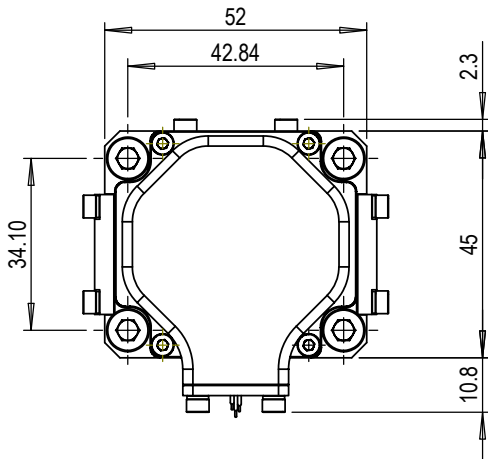

Mounting interface conforms to ISO 10372-02-02-0-92									
	P	C1	C2	R	F1	F2	F3	F4	G
size	$\varnothing 5$	$\varnothing 5$	$\varnothing 5$	$\varnothing 5$	M5	M5	M5	M5	$\varnothing 3 \nabla 5$
x	21.40	13.50	29.30	21.40	0	42.80	42.80	0	11.50
y	9.20	17.10	17.10	25	0	0	34.20	34.20	4.40
Surface flat within 0.01 / 100 : finish better than 0.8 μm									

